

LED Driver and Temperature Controller Model DLT-27

• Driver **DLT-27** is designed for power supply of all models Mid-IR LED's with built-in thermocoolers. Driver provides two modes of operation:

- Quasi Continuous Wave (quasi steady-state) mode. Such mode provides maximum average optical power from the LED. Current in this mode can be changed in the range 20-400 mA. Frequency of modulation is 16 kHz.

- Pulse mode. Such mode provides maximum peak optical power from the LED. Peak current in pulse mode can be changed in the range 0-2 A. Pulse duration is 1 μs

- Temperature controller that is built in DLT-27 provides selecting and stabilizing of the temperature on LED's chip in wide range. That gives possibility to tune wavelength or optical power.

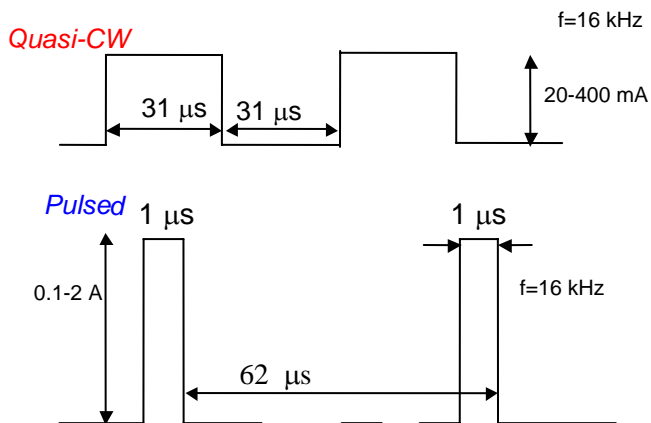

Frequency can be changed accordingly the customer's request. Also at the using of photoresistor of PR43 model the frequency must be changed on 10 μs .

Parameters	Pulse mode	Quasi-CW mode
Pulse duration	1 μs	31 μs
Repetition rate	16 kHz	16 kHz
Current amplitude	0.1-2 A	20-400 mA
Dimensions, mm	145x70x30	
Weight	200 g	
Power requirement	stabilize +12 V DC \pm 5%	

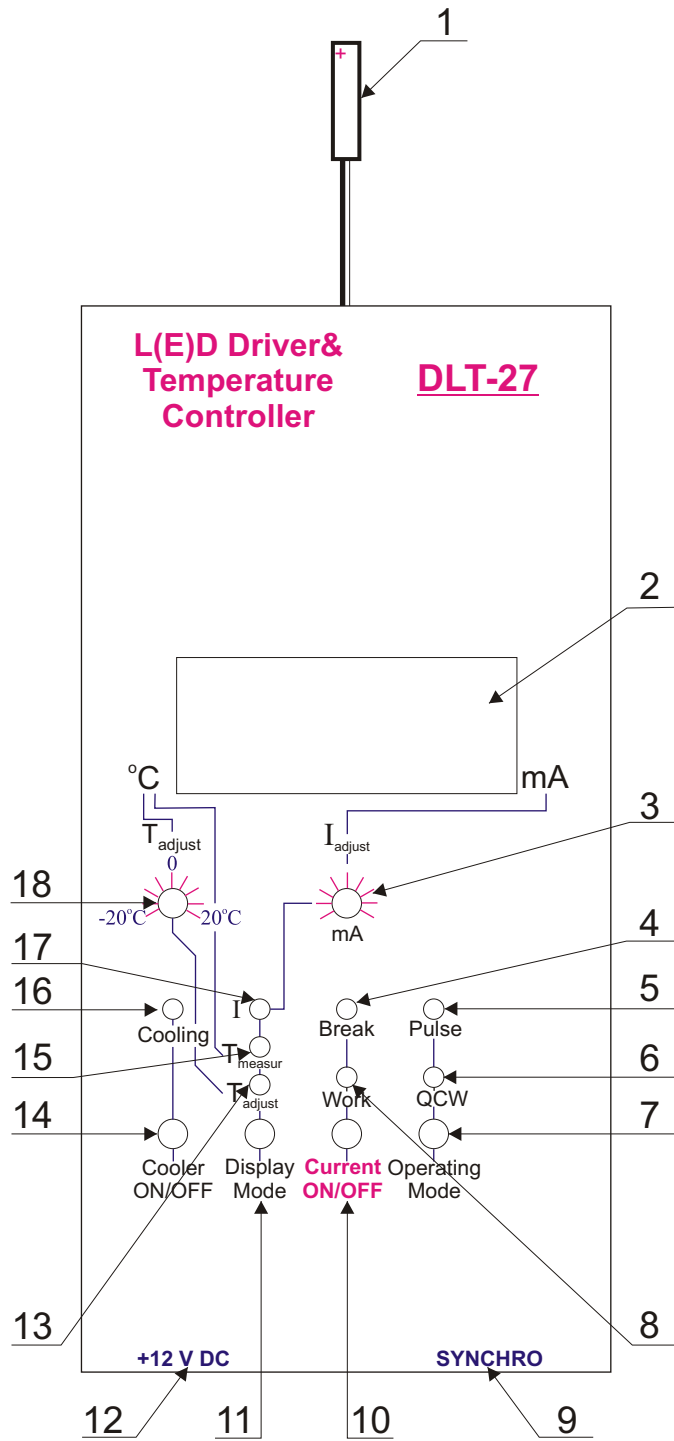

DLT-27 for LEDs with thermocoolers
(LEDXX-TEC and LEDXX-TEC-PR models)

Operating instruction

1. Insert LED with thermocooler into connector "LED" (1) (Attention on voltage polarity - + to the red point on the LED package).

2. Insert AC/DC adapter into connector "+12V DC" (12) (Attention on voltage polarity).

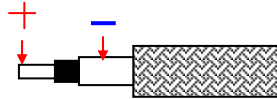

3. If necessary connect "SYNCHRO" (9) with selective amplifier of the detector signal (Attention on voltage polarity).

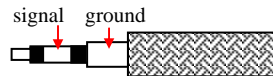

4. Select operating mode - "QCW" or "Pulse" (switch "Operating mode" - 7). Green LED will indicate selected mode "Pulse" (5) or "QCW" (6)
5. Switch "Display Mode" (11) to the position "T_{adjust}" (13).
6. Select temperature of LED's operation by adjusting on Switch "T_{adjust}" (8). We recommend to begin with temperature +20C. You will see on the LC display (2) selected temperature.
7. Switch "Display Mode" (11) to the position "T_{measur}" (15). You will see on the LC display (2) real (measured) temperature on the LED chip.
8. Switch on thermocooler (14). Green LED (16) will indicate that cooling is working. You will see new measured temperature on the Laser Diode chip on LC display (2).
9. Switch "Display Mode" (11) to the position "I" (17).
10. Set minimum current on Switch "I_{adjust}" (3).
11. Switch on driver (switch "Current On/Off" (10)). Green LED "Work"(8) will indicate that current is flowing. You will see on the LC display (2) drive current through the laser chip in miliAmps. If after switching on current is not flowing red LED "Break"(4) will indicate break of the circuit. That situation can take place if testing Infrared LD is damaged.
12. Select drive current that you need by Switch "I_{adjust}" (3).